

point2point AC and DC Coupled Fibre Optic Links

User Guide

Pxx-HB-3



CR4635

02/12/2020



TABLE OF CONTENTS

1	SAFETY INFORMATION	3
1.1	Electrical Safety	3
1.2	Optical Safety.....	3
2	IMPORTANT HANDLING INSTRUCTIONS	4
2.1	Connecting Fibre Optic Connectors	4
2.2	Disconnecting Fibre Optic Connectors	4
2.3	Care of Fibre Optic Connectors	4
2.4	Bend Radius.....	4
3	INTRODUCTION	5
3.1	Fibre Optic Cable	5
3.2	Transmitter Module.....	5
3.3	Receiver Module	5
4	SETTING UP A POINT2POINT LINK	6
4.1	Module Operation	6
4.1.1	Shielded Remote Modules.....	6
4.1.2	Rack Plug-in Modules.....	6
4.1.3	Plug-in Converter Sleeve.....	6
4.1.4	Transmitter Analogue Signal Input.....	6
4.1.5	Receiver Analogue Signal Output.....	6
4.2	System Integration	7
4.2.1	DC Link	7
4.2.2	AC Link.....	8
5	BATTERY PACKS	9
5.1	Battery Pack Operation.....	9
5.2	Battery Pack Charging.....	9
5.3	External Power Lead.....	9
5.4	Shielded mains PSU	9
6	MAINTENANCE AND FAULT-FINDING GUIDE	10
7	PART NUMBERING	11
7.1	Accessory Part Number Guide.....	11
8	PRODUCT WARRANTY	19

1 Safety Information

*Please read the whole of this section before using your **point2point** product.*

1.1 Electrical Safety

The Rack Cases that are used in conjunction with the DC Digital Link family are Safety Class 1 instruments (they have a metal case that is directly connected to earth via the power supply cable).

When operating the equipment note the following:



- Hazardous voltages exist within the equipment.
- Do not remove equipment covers when operating.
- Make sure that only fuses of the required rated current and of the specified type (anti-surge, quick blow, etc.) are used for replacement.
- There are no user serviceable parts inside this unit.



- Precautions for handling electro-static sensitive devices should be observed when handling modules

1.2 Optical Safety



The **point2point** DC analogue transmitter **singlemode** modules contain laser diode sources operating at 1310nm. These devices are rated at under IEC60825-1 as CLASS 1 radiation emitting devices.

The **point2point** DC analogue transmitter **multimode** modules contain laser diode sources operating at 850nm. These devices are rated at under IEC60825-1 as CLASS 1 radiation emitting devices.

When operating the equipment note the following:

- Never look into the end of an optical fibre or connector directly or by reflection either with the naked eye or through an optical instrument.
- Never leave equipment with radiating bare fibres accessible – always cap the connectors.
- Do not remove equipment covers when operating.

Adjustment, maintenance and repair of the equipment should only be carried out by suitably qualified personnel.

2 Important Handling Instructions

2.1 Connecting Fibre Optic Connectors

The fibre optic cable supplied with your **singlemode** AC or DC link is terminated with **FC/APC** narrow key screw-type connectors. FC/APC connectors are high precision screw type connectors and should only be finger tightened. This type of cable should not be confused with FC/PC type connectors supplied with older equipment.

The fibre optic cable supplied with your **multimode** 2.5MHz DC link is terminated with **ST** bayonet-type connectors.

The optical connectors should be cleaned in accordance with the instructions in the Fibre Optic Cleaning Kit Handbook (7279x-HB) **before each and every** connection, even if they have been protected with dust caps.

The protective dust caps on the equipment and cable connectors should only be removed immediately before the connectors are mated.

Care should be taken not to drop the optical connector or to subject it to any other excessive physical shock.

2.2 Disconnecting Fibre Optic Connectors

The connectors should be removed by unscrewing and withdrawing the connector.

UNDER NO CIRCUMSTANCES SHOULD THE FIBRE BE PULLED TO REMOVE THE CONNECTOR.

Immediately after removing the connectors, all protective dust covers and end caps should be fitted.

2.3 Care of Fibre Optic Connectors

When the fibre optic cables are not connected, it is essential that the cable and equipment connectors are protected by the dust caps provided with the system. Failure to do so may result in damage to the fibre ends, which are critical to the system performance.

System performance may be compromised by dirt on the connector end or its alignment surfaces. Refer to the Fibre Optic Cleaning Kit Handbook (7279x-HB) for instructions on cleaning the optical connectors.

Connector performance will be compromised if its end face is scratched or chipped.

2.4 Bend Radius

All fibre optic cable is subject to a minimum bend radius beyond which physical damage may occur to the cable. The minimum recommended bend radius for **point2point** fibre optic cables is 30cm.

3 Introduction

The **point2point** links are a family of non-galvanic link systems designed for the transmission of analogue signals from true DC up to 3GHz in electrically noisy environments.

The system consists of a transmitter module, which converts the input electrical signal to an optical signal, a fibre optic cable down which the signal is conveyed, and a receiver module which recovers the original signal.

3.1 Fibre Optic Cable

The fibre optic cables used in conjunction with the **singlemode point2point** links are terminated with a single FC/APC narrow key optical connector at each end.

The fibre optic cables used in conjunction with the **multimode point2point** DC links are terminated with a single ST optical connector at each end.

Refer to the Fibre Optic Cleaning Kit Handbook (7279x-HB) for instructions on cleaning the optical connectors.

Connector performance will be compromised if its end face is scratched.

3.2 Transmitter Module

The transmitter module contains the signal conditioning circuitry, optical transmitter, power supply filtering/regulation and basic control circuitry.

The optional battery pack (shielded remote housing option only) attaches to the side of the transmitter module and provides electrical power to the transmit electronics. Battery packs are quickly and easily changed; this enables the system to be operated continuously, with minimum delays whilst batteries are charged. Spare battery packs can be separately ordered (see Accessories).

3.3 Receiver Module

The receiver module receives the optical signal from the transmitter module, and converts it back into an analogue electrical signal.

The optional battery pack (shielded remote options only) attaches to the side of the receiver module and provides electrical power to the receive electronics.

4 Setting Up a point2point Link

This section describes the connections between your fibre optic link transmitter and receiver modules, and the operation of both units in a system.

4.1 Module Operation

4.1.1 Shielded Remote Modules

The module is switched on automatically by connection to a fully charged battery pack using the battery pack U-Link or batter switch module. Removal of the link powers down the module. Refer to Appendix III for mechanical drawings.

4.1.2 Rack Plug-in Modules

The module is powered up when the rack unit is switched on at the on/standby switch.

4.1.3 Plug-in Converter Sleeve

The module is powered up when the rack plug-in module is plugged into the sleeve, and the 12V power supply is plugged into the 2.1mm connector socket on the rear of the converter sleeve.

4.1.4 Transmitter Analogue Signal Input

The user's signal is applied to the signal input on the transmitter module. Maximum ratings for this input are given in the technical specifications in Appendix II.

If the maximum ratings are exceeded, the status (S) LED on the transmitter module front panel will illuminate red. If this occurs, the input signal will be distorted on recovery at the receiver module.

4.1.5 Receiver Analogue Signal Output

The measured signal is retrieved from the signal output connector (see diagram). Depending on receiver version different load should be connected to the output

4.1.5.1 $\pm 2V$ Output Receiver Models

The output voltage is calibrated assuming 50 Ω load. Thus, to read correct value, input impedance of the scope should be set to 50 Ω . If using high impedance probe, output of the receiver should be terminated with 50 Ω resistor.

Note that if the output is not terminated, then the voltage measured at the output will appear approximately two times larger than expected.

4.1.5.2 $\pm 10V$ Output Receiver Models

The output voltage is calibrated for 1M Ω load. Other load value can cause incorrect readings.

Note: The output impedance of the receiver together with the capacitance of connected cable and input capacitance of the scope creates a low pass filter which can change frequency response. In the table below one can find attenuation for different capacitance values. To reduce this influence it is essential to avoid long measurement cables (typical capacitance of 50 Ω coaxial cable is approx. 100pF/m).

Capacitance [pF]	Attenuation @ 2.5MHz [dB]
50	0.25
100	0.9
150	1.8
200	2.8

Output impedance, maximum current ratings and level specifications can be found in 0.

4.2 System Integration

The diagram below illustrates a typical system configuration comprising a shielded remote transmitter module and rack plug-in receiver module. The electrical source is a function generator and the recovered signal is displayed on an oscilloscope.

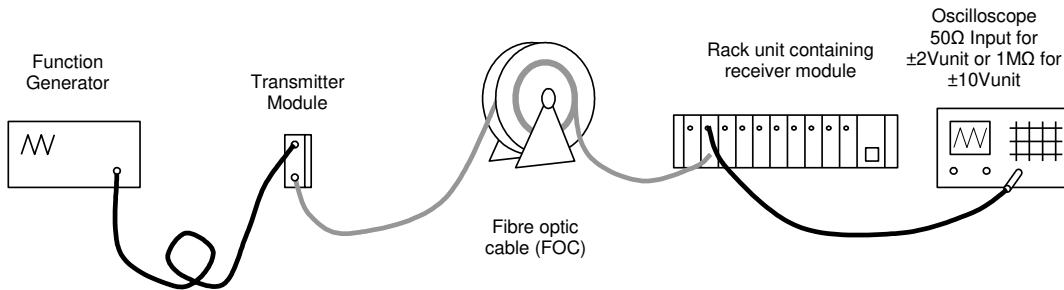

The sequence in which the equipment is initially set up to make a measurement is not critical, though it is recommended that the fibre optic cable is attached to both transmitter module and receiver module before the transmitter module is powered up. This way, there is no optical hazard presented by laser light propagating through a free end of the fibre.

4.2.1 DC Link

When the transmitter and receiver modules are connected via the FOC and switched on, the status LED on the receiver will flash until the connection has been established. Due to the method used for synchronisation between transmitter and receiver there is no defined time to establish connection, but usually it takes no longer than 10s. On very rare occasions it could last up to 20s. If it takes longer, turn off the units, check the fibre connection and turn on the units once again.

A flashing status LED on the receiver shows that the receiver is attempting to lock to the transmitter signal. If a signal cannot be found (e.g. transmitter is not turned on or no fibre is connected to the receiver) the LED will continue to flash. Once connection has been established and receiver is in the lock state the status LED will turn green. At this point the signal presented at the transmitter module input is mirrored at the output of the receiver module.

In the situation where the receiver module is operating without the transmitter module being in place, for example while changing the battery pack on a shielded remote transmitter module, the receiver module output voltage will be held to 0V.

Once a lock has been re-established, the LED will illuminate green and the transmitter module input signal will reappear at the receiver module output.

Due to the technology used, the **point2point** range of DC coupled analogue fibre optic links is extremely tolerant to fluctuations in insertion loss in the optical path. The signal to noise ratio and system gain remain unaffected by path loss over a very wide range of fibre lengths and attenuations.

While increased optical path loss does not have an apparent effect on the link integrity, optical connector cleanliness is as important with these links as with any other. Please refer to the Fibre Optic Cleaning Kit Handbook (7279x-HB) for instructions on how to correctly maintain your product.

While the DC coupled analogue fibre optic link is a system for transmitting analogue information, the transmission method used is digital. This means that, in practice, the links are extremely tolerant to fluctuations in insertion loss in the optical path while the signal to noise ratio and system gain remain unaffected. Exceeding the maximum path length will result in a rapid degradation of signal integrity or loss of signal.

While small increases in optical insertion loss do not have an apparent effect on the link integrity, optical connector cleanliness is as important with these links as with any other. Please refer to the Fibre Optic Cleaning Kit Handbook (7279x-HB) for instructions on how to clean the fibre optic connectors.

4.2.2 AC Link

When the transmitter module and transmitter module are connected via the fibre optic cable and powered up, the status LED on the receiver indicates the level of signal received from the transmitter.

The power (P) LED has the following functions on AC links:

Power LED	Rack plug-In	Shielded remote
Green	OK	Battery voltage OK
Red	n/a	Battery voltage is Low.
Off	Rack not switched on	Battery is discharged or not connected

The Status LED has the following function on AC links:

Status LED	All housing variants
Green	Link gain >-3dBr
Flashing green/red	-10dBr < Link gain <-3dBr
Red	Link gain <-10dBr

The link gain (Transmitter input to receiver output) depends on the following factors:

- Transmitter gain (options include 0dB, +20dB)
- Receiver gain (options include 0dB, +10dB)
- Optical path Loss (due to connector insertion loss and optical fibre loss)

For clean, undamaged super-polished single-mode FC/APC connectors, the **optical** insertion loss is typically 0.4dB. The losses at the optical connections at the Transmitter and Receiver are allowed for during manufacture of the module, and may be ignored during link gain calculations.

For singlemode fibre (e.g. Siecor SMF28), the **optical** loss at the 1300nm operating wavelength of the **point2point** AC Analogue links is 0.4dB/km. This is increased if the fibre is under excessive tension, compression or is bent into a small radius.

The additional **electrical** insertion loss resulting from **optical** losses is equal to 2x that of the **optical** loss. This is due to the physics of the opto-electrical conversion process in the receiver.

For short links (<250m) containing no additional optical connectors, and in which the fibre is not subject to any strain, then the optical path loss can be ignored.

The actual link gain can be determined as follows:

$$\text{Link Gain} = \text{Tx Gain} + \text{Rx Gain} - 2 * (\text{optical connector insertion losses} + \text{fibre losses}) \text{ [dB]}$$

Example 1

Transmitter with 0dB gain (0dBm maximum input)

Receiver with +10dB gain (+10dBm maximum output)

Optical path length 8km of SMF28 optical fibre with no additional optical connectors. This results in a path optical loss of 3.2dB.

$$\text{Link Gain} = 0 + 10 - 2 * 3.2 = +3.6\text{dB}$$

Because the optical path loss results in an electrical gain reduction of >3dB, the receiver status LED flashes red/green.

Example 2

Transmitter with 0dB gain (0dBm maximum input)

Receiver with 0dB gain (0dBm maximum output)

Optical path length 8km of SMF28 optical fibre with 6 additional optical connectors. This results in an optical loss of $8 \times 0.4 + 6 \times 0.4\text{dB} = 5.6\text{dB}$.

$$\text{Link Gain} = 0 + 0 - 2 * (5.6) = -11.2\text{dB}$$

Because the optical path loss is high, resulting in an electrical gain reduction of >10dB, the receiver status LED is a constant red.

5 Battery Packs

The *point2point* range of fibre optic links can be powered from shielded battery packs. There are two sizes of battery pack available, the standard pack and the high capacity (refer to Appendix III for mechanical drawings).

5.1 Battery Pack Operation

The battery packs used on the DC Link shielded remote modules provide a nominal output voltage of 14.4V. A fully charged battery pack may have an open circuit voltage of more than 17V.

The battery packs are attached to the shielded module by locating a "lug" in one end of the pack into a slot on the module, then using a rigid screened battery "u-link" adapter to secure the two parts. This connector should be finger tightened for best screening performance.

When a fully charged battery pack is attached to a module, the module automatically powers up. This is indicated by the power (P) LED illuminating green. As the batteries reach the end of their discharge cycle, the power LED will illuminate red to warn the user that the module will power down shortly. The module will continue to function in this mode without performance impairment for several minutes allowing measurements to be completed

When a battery pack becomes fully discharged, the module to which it is attached will shut down. At this point, it is necessary to replace the battery pack with one that is fully charged.

Optical transmitter modules should not be left with the battery pack attached for extended periods, as this may over-discharge the battery pack, causing permanent damage.

More information on the battery pack including battery pack Care and Charging can be found in the *point2point* battery and charger handbooks.

5.2 Battery Pack Charging

To charge a battery pack it should be removed from the shielded module and connected to the battery charger as shown below.

Please refer to battery handbook and charger hand book to ensure that a charger compatible with the battery type is being used

Fast charging can simply be achieved by turning the charger on and connecting the batteries to the charger with the supplied leads. The charger automatically controls and charges each battery connected.

Full details of operation are given in the battery and charger handbooks

5.3 External Power Lead

There are applications where access is required to a suitable regulated DC power source where the shielded module is located. In this instance, a shielded cable PPM part number 73613 is provided for connection to a user power supply.

The power supply must conform to the requirements of the shielded module.

<i>Parameter</i>	<i>Minimum</i>	<i>Rated</i>	<i>Maximum</i>
<i>Voltage</i>	13.0V _{DC}	14.5V _{DC}	16V _{DC}
<i>Current</i>	2A *	-	-
<i>Ripple</i>	-	-	75mV

- A 2.5A anti-surge fuse must be provided in-line.

5.4 Shielded mains PSU

Where an AC power source is available it is also possible to run the system from a shielded power supply module (part number 73503). Refer to Appendix III for mechanical drawing.

6 Maintenance and Fault-Finding Guide

The following table gives a list of commonly encountered problems and suggested solutions.

Fault	Possible Causes	Solution
Illuminated power switch does not illuminate on the rear of the Rack case unit.	Power is not attached to the rack unit. Mains switch is turned off. Fuse has blown in rack unit.	Connect mains power to the rack unit, and switch on power. Switch on mains switch. Replace fuse (2A anti-surge).
Power LED does not light on shielded remote Module when battery pack is attached.	Battery pack is discharged. Battery pack U-link is not fitted at rear of module.	Recharge/replace battery pack. Attach battery pack U-link.
Power LED on shielded remote Module illuminates red.	Battery pack power is low. External power supply voltage is low.	Recharge/replace battery pack. See specifications for allowable range of supply voltages.
Power LED does not light on rack plug-in module.	Rack unit is not powered. Rack mount module is not correctly plugged into rack unit.	Connect mains power to the rack unit, and switch on power. Power down rack unit, Push module fully home, Re-apply power to rack unit.
Receiver status LED is flashing	Dirt on the fibre optic connectors. Broken optical fibre. Transmitter is off	Clean the fibre optic connector. Refer to the Fibre Optic Cleaning Kit Handbook (7279x-HB). Contact PPM. Turn on the transmitter
Transmitter module status LED is illuminated red.	Over voltage on transmitter module input.	Reduce input voltage.

The **point2point** range of transmitter and receiver modules are calibrated for optimum performance and accuracy before dispatch. In order to guarantee the continued performance and reliability of the link, it is strongly recommended that your fibre optic link be returned to PPM for calibration annually.

In the event of any problems or queries about the equipment, contact PPM or your local agent.

7 Part Numbering

For part numbering please refer to the relevant datasheet which can be found on our website or contact us.

7.1 Accessory Part Number Guide

Below are the part numbers of point2point accessories.

Enclosures	
SRK-1	3U high Desktop Case
SRK-2	3U high Subrack
SRK-3	4U high Desktop Case
SRK-1 / SPL-1	3U high Desktop Case with Switch Plate (for <i>point2point</i> only)
SRK-2 / SPL-1	3U high Subrack with Switch Plate (for <i>point2point</i> only)
SRK-3 / SPL-1	4U high Desktop Case with Switch Plate (for <i>point2point</i> only)
SRK-3P	Cooled 4U 19" for Test & Instrumentation +SPL1
SRK-3R	Cooled 4U 19" Cabinet mounting, rack mounted
SRK-3RP	Cooled 4U 19" Cabinet mounting, rack mounted + SPL1
73680	Single channel battery optical switch
73681	Four channel battery switch control module
75002	7hp Standalone Converter Sleeve
75011	1U high Subrack
75013	Power sleeve with 9.0Ah capacity
75014	Power sleeve with 3.6Ah capacity
75015	Power sleeve with 9.0Ah capacity, with optical switch
75016	Power sleeve with 3.6Ah capacity, with optical switch

Controllers	
SPL-1	Switch Plate

Power Supplies & Battery Packs	
73512	High Capacity NiMH Battery Pack with U-Link
73511	Standard Capacity NiMH Battery Pack with U-Link
55733	NiCd Battery U-Link
73469	Battery Charging Lead
73502	Converter Sleeve PSU
73613	External Power Lead 1m
56292	Four Channel Fast NiMH Battery Charger with Charging Leads

Fibre Optic Cable	
F1R1/x	ST Fibre optic cable, x metres in length (multimode 50/125um)
F4R1/x	FC/PC Fibre optic cable, x metres in length (singlemode 8/125um)
F5R1/x	LEMO Fibre optic cable, x metres in length (singlemode 8/125um)
F6R1/x	FC/APC Fibre optic cable, x metres in length (single mode 8/125um)
F8R1/x	ST Fibre optic cable, x metres in length (multimode 62.5/125um)

Appendix I Specifications

System Electrical Performance (at 25°C unless otherwise noted)

DC Links		PDx-Rx-6x PDx-Rx-1x	PDx-Tx-6x	PDx-Ux-6x
Passband		DC to 2.5MHz	DC to 20MHz	DC to 40MHz
Flatness		DC-1MHz : $\pm 0.5\text{dB}$ DC-2MHz : $\pm 1\text{dB}$ DC-2.5MHz : $\pm 3\text{dB}$	DC-2MHz : $\pm 0.25\text{dB}$ DC-15MHz : $\pm 1\text{dB}$ DC-20MHz : $\pm 3\text{dB}$	DC-10MHz : $\pm 0.25\text{dB}$ DC-30MHz : $\pm 1\text{dB}$ DC-40MHz : $\pm 3\text{dB}$
Risetime		<135ns	<20.5ns	<10.3ns
2 nd harmonic distortion @5MHz, 4Vpp			-59dBc	-63dBc
3 rd harmonic distortion @5MHz, 4Vpp			-69dBc	-75dBc
Noise (full band RMS)		0.3mV (PDR-R1-xx) 1.5mV (PDR-R2-xx)	0.8mV	0.7mV
Phase Flatness		< $\pm 10^\circ$		
Signal Latency		350ns	280ns	210ns
Output Noise (Full Band)		<0.3mV _{RMS} , $\pm 2\text{V}$ FSD <1.5mV _{RMS} , $\pm 10\text{V}$ FSD	<0.8mV _{RMS} , $\pm 2\text{V}$ FSD	<0.7mV _{RMS} , $\pm 2\text{V}$ FSD
Transmitter Input Impedance		1M Ω //25pF typ.		
Receiver Output Impedance		50 Ω (PDR-R1-xx) 300 Ω (PDR-R2-xx)	50 Ω	50 Ω
Transmitter Input Voltage Range		$\pm 2\text{V}$ standard $\pm 10\text{V}$, $\pm 20\text{V}$, $\pm 50\text{V}$, $\pm 100\text{V}$ & $\pm 150\text{V}$ options		
Receiver Output Voltage Range		$\pm 2\text{V}$ @ 50 Ω (PDR-R1) $\pm 10\text{V}$ @ 1M Ω (PDR-R2)	$\pm 2\text{V}$ into 50 Ω load	$\pm 2\text{V}$ into 50 Ω load
Output DC Temperature Drift	TX	0.06mV/ $^\circ\text{C}$	0.06mV/ $^\circ\text{C}$	0.06mV/ $^\circ\text{C}$
	RX	0.15mV/ $^\circ\text{C}$ (PDR-R1) 0.6mV/ $^\circ\text{C}$ (PDR-R2)	0.15mV/ $^\circ\text{C}$	0.15mV/ $^\circ\text{C}$
Output DC Offset		< 0.3% of FSD		
Nonlinearity		< 0.1%	< 0.1%	< 0.06%
Operating Temperature		-20 $^\circ\text{C}$ to +60 $^\circ\text{C}$		
Optical path length		<10km for singlemode <500m for multimode		
Optical fibre type		Singlemode: 8/125 Multimode: 50/125 or 62.5/125 graded index, <2.5dB/km, >400MHz.km		
Electrical Signal Connector		BNC		
Optical Signal Connector		FC/APC singlemode Or ST multimode		
Front Panel Indication	TX	Power supply status & Input over-range warning		
	RX	Power supply status & link lock status		
Supply Voltage	Shielded module Plug-in module	13 - 15Vdc 12Vdc		
Current Consumption @12V (no input signal present)	TX	<240mA	<240mA	<210mA
	RX	<350mA	<315mA	<280mA
Housing Options		Shielded module OR Plug-in module		
Plug-in Case Suitability		SRK-2, SRK-2P, SRK-3P, SRK-3RP, 75011, 75002, 75013, 75014, 75015, 75016		

RF System Parameters (at 25°C unless otherwise noted)

AC links	PAx-Gx-6x	PAx-Kx-6x	PAx-Px-6x	PAx-Sx-6x
Bandwidth (-3dB)	40Hz to 250MHz	2kHz to 1.35GHz	1MHz to 2GHz	10MHz to 3GHz
Risetime (10-90%)	<1.4ns	<350ps	<250ps	<200ps
Jitter (measured on a 100MHz sine wave)	<10ps RMS	<10ps RMS	<10ps RMS	<10ps RMS
Simultaneous Dynamic Range @100MHz	>150dB in a 1Hz bandwidth	>150dB in a 1Hz bandwidth	>150dB in a 1Hz bandwidth	>147dB in a 1Hz bandwidth
Electrical Link Gain, Nominal	See section 3.2.2			
Gain Stability	<±0.25dB after 20 minute warm up			
Passband Flatness	40Hz - 100kHz : ±1.5dB 100kHz - 250MHz : ±0.75dB	2kHz - 100kHz : ±1.5dB 100kHz - 1.35GHz : ±1dB (typ 0.5dB)	±1dB	±1dB
Phase Flatness	> 100Hz : ±20°	> 5kHz : ±20°	±20° (typical ±5° for 1MHz to 1.5GHz)	±20° (typical ±5° for 1MHz to 1.5GHz)
Noise Figure	< 22dB @ 100MHz	< 25dB @ 500MHz	< 25dB @ 500MHz < 30dB @ 2GHz	< 26dB @ 500MHz < 30dB @ 3GHz
Max. input for <2% distortion	500mVpk-pk, 250mVpeak, 180mVRMS, -2dBm			
Input P1dB	> 0dBm @ 100MHz	> 0dBm @ 500MHz		
Input IP3	>10dBm @ 100MHz	>10dBm @ 500MHz		
Signal delay	5ns (+/-10%) per module + 5ns/metre delay through the cross-site optical fibre			
Signal inversion	Inverting			
Absolute maximum input	+3dBm continuous and >+15dBm, 5Vdc non-continuous			
Input/Output Impedance, VSWR	50Ω, ≤2:1			
Operating Temperature	-10°C to +40°C			
Electrical signal connector	SMA female			
Optical signal connector	Singlemode FC/APC Narrow key, >60dB return loss, HUBER+SUHNER FCPC-Z/M-A601			
Optical Fibre Type	Singlemode SMF-28 or equivalent			
Optical Fibre Bend Radius	30cm min.			
Supply voltage	13 - 15Vdc			
Shielded module	12Vdc			
Plug-in Module				
Current consumption	<250mA Tx, <150mA Rx			
Housing options	Shielded module Plug-in module Standalone module (using 75002)			
Plug-in rack case suitability	SRK-1, SRK-2, SRK-3, SRK-3R			

Appendix II Accessories

F1R1/1	1m Multimode fibre optic cable 50/125, ST connectors /10 (=10m), /50. For custom lengths, contact PPM
F6R1/1	1m Single-mode fibre optic cable, FC/APC connectors /10 (=10m), /50. For custom lengths, contact PPM
73481	Cable management reel, standard
73482	Cable management reel, large
73511	Standard capacity battery 2.0Ah Pack + battery linking plug
73512	High capacity battery 3.6Ah pack + battery linking plug
56292	Battery charger + 4 charging leads
55733	Battery linking plug
55755	Battery linking plug with extra rear DIN47295 port
SRK-3P/-3RP	19" 4U Cooled desktop cases/subracks
SRK-2/-2P	19" 3U Cooled desktop cases /subracks
75011	19" 1U Rack for 3 plug-in modules
75002	Plug-in module converter sleeve (for stand-alone use)
73502	Mains power supply for converter sleeve
75013	Plug-in module PowerSleeve 9Ah NiMH battery
75014	Plug-in module PowerSleeve 3.6Ah NiMH battery
75015	Plug-in module PowerSleeve 9Ah NiMH battery + optically controlled switch
75016	Plug-in module PowerSleeve 3.6Ah NiMH battery+ optically controlled switch
73680	Switch, battery load, point2point
73681	Module, battery controller, 4 channel
73401	Battery switch lead, DIN47295 to 2.1mm power plug
73402	Battery switch lead, DIN47295 to bare end

Appendix III Drawings

Shielded remote Module – typical for both Rx and Tx DC configurations.

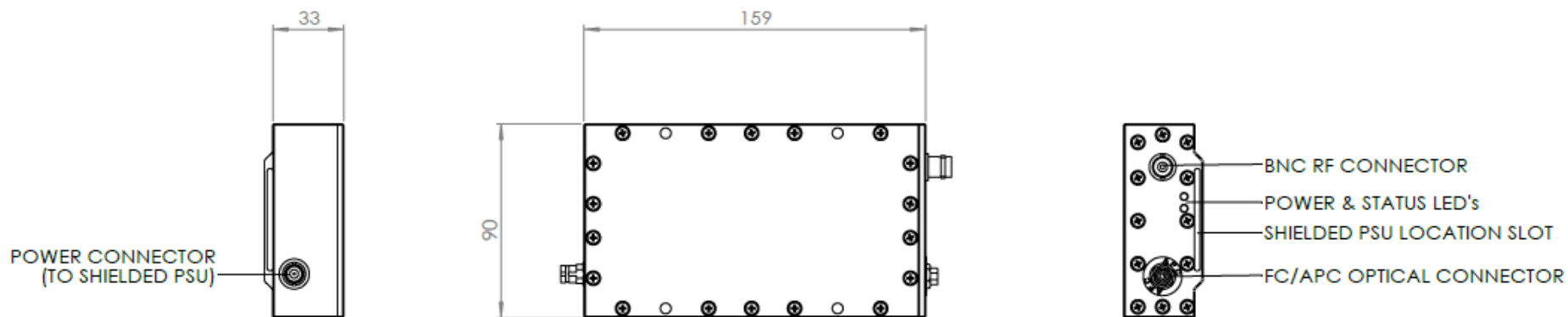
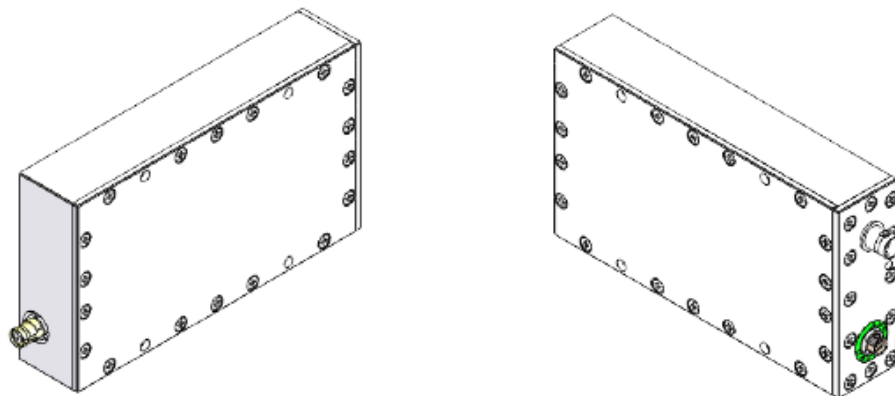

Shielded Power Supply Module 73503

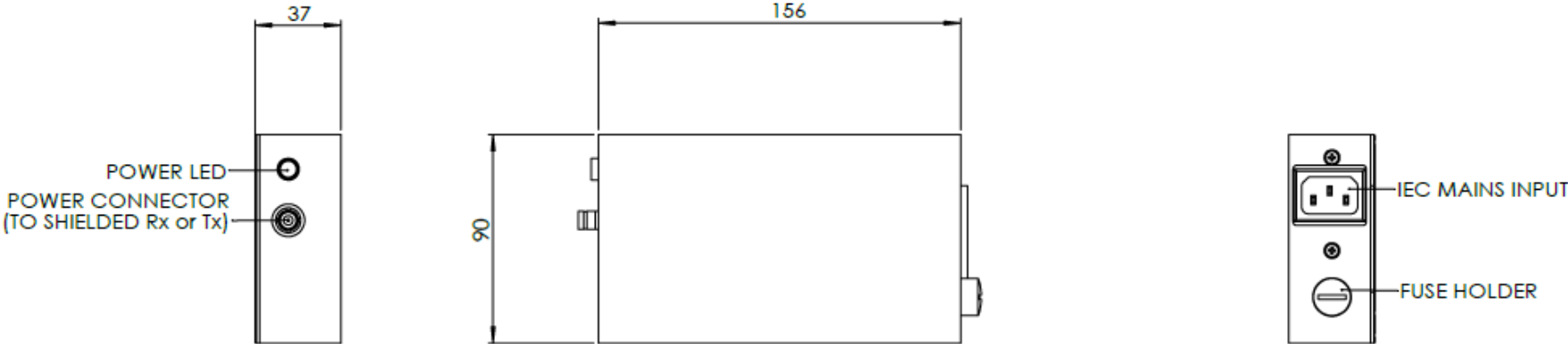
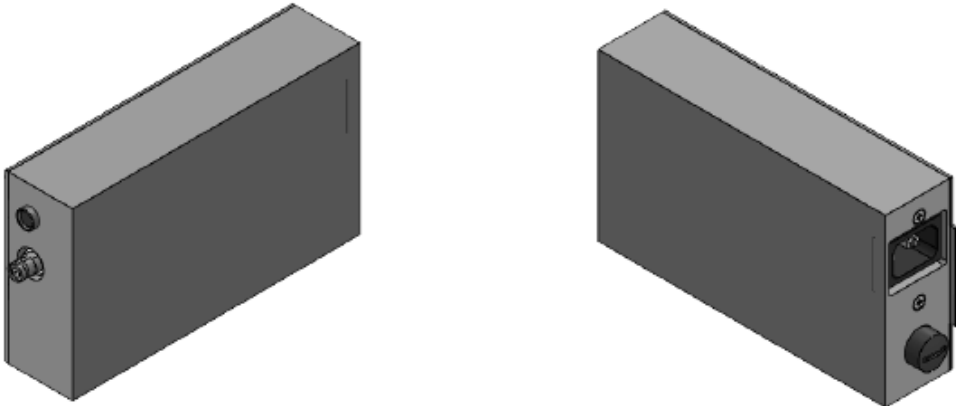

Shielded standard battery pack (2.0Ah) 73511
(includes battery link plug 55733)

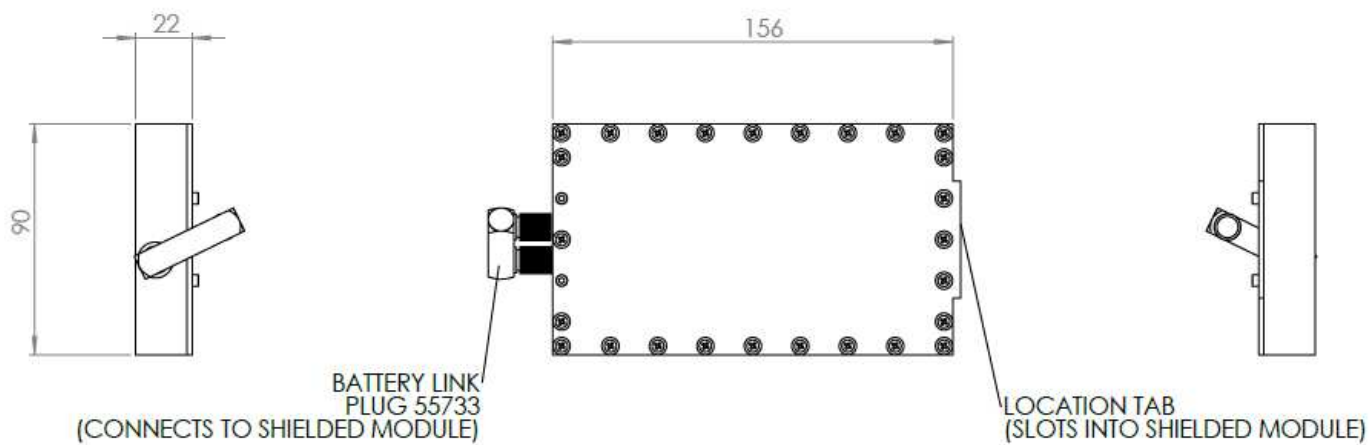
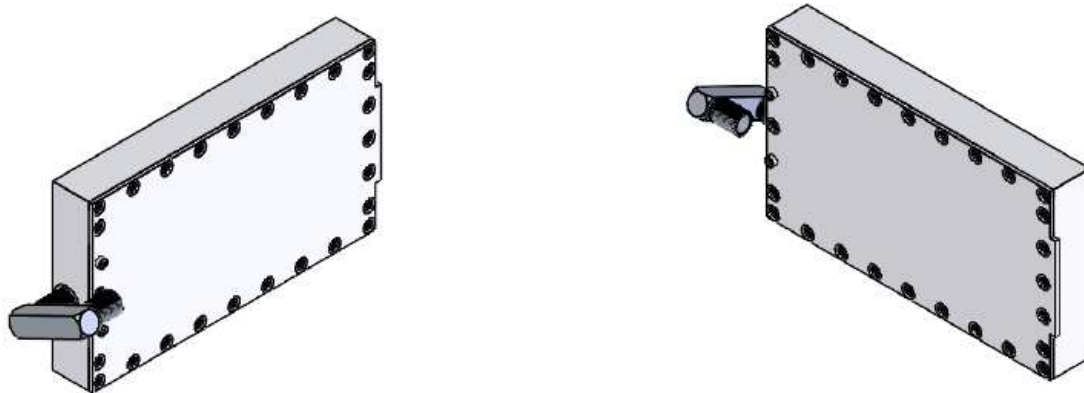

Shielded high capacity battery pack (3.6Ah) 73512
(includes battery link plug 55733)

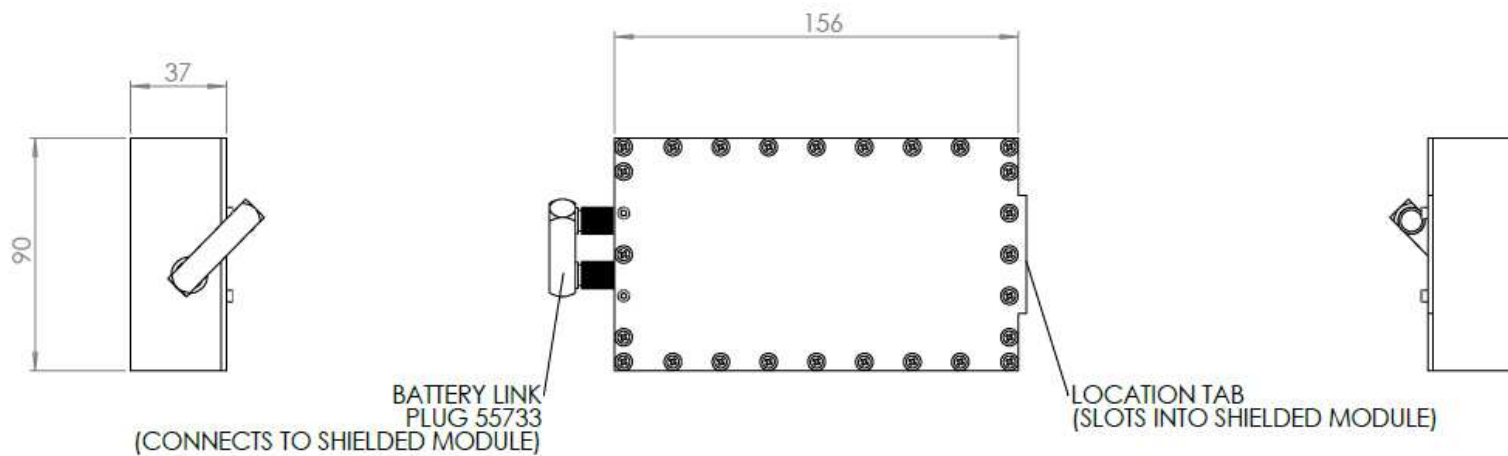
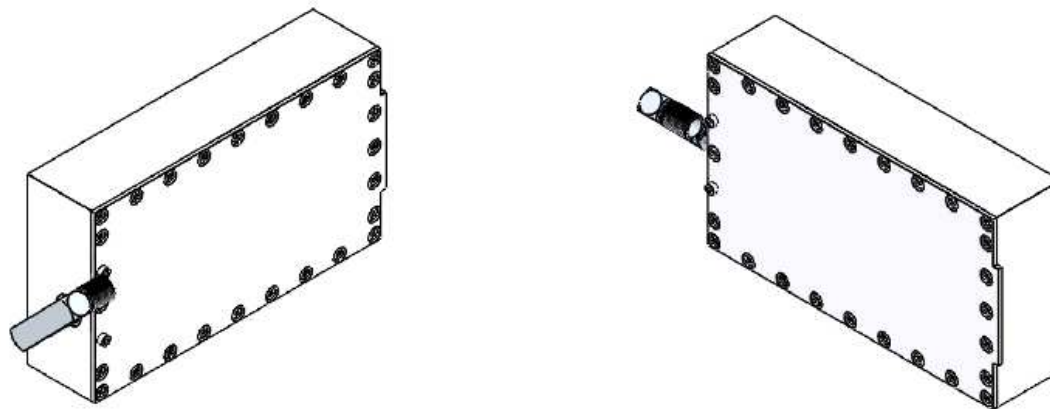

8 Product Warranty

The guarantee / warranty period, unless otherwise agreed in writing, shall be as stated in document F292 - PPM Manufactured Product – Warranty, which is available at: <https://ppm.co.uk/warranty-periods/>. Extended warranty options are available at the time of purchase.

Prior to returning any goods for warranty or non-warranty repairs please contact PPM / **ViaLite Communications** for a returns reference.

© PULSE POWER & MEASUREMENT LTD 2020.

NO PART OF THIS DOCUMENT MAY BE REPRODUCED OR TRANSMITTED IN ANY FORM WITHOUT PRIOR WRITTEN PERMISSION.
PULSE POWER & MEASUREMENT LTD (PPM), 65 SHRIVENHAM HUNDRED BUSINESS PARK, SWINDON, SN6 8TY, UK.

TEL: +44 1793 784389

FAX: +44 1793 784391

EMAIL: SALES@PPMTEST.COM

WEBSITE: WWW.PPMTEST.COM